



ASSEMBLE-IN-THE-FIELD SENSING EDGE

CE MODEL: CPT215

WARNING

Read and understand all instructions before beginning installation. Disconnect power to motor and test upon completion. Sensing edges should be installed by qualified personnel to ensure the requirements herein have been met. Keep these instructions with the installation. Always abide by local and national electrical code specifications when wiring accessories to motor controls.

CPT215 is a UL 325 recognized sensing edge designed for on-site configuration and assembly. Upon contact with an obstruction, CPT215 signals operator controls to immediately stop and/or reverse motion. With no adhesive required, the CPT215 end design allows for field length adjustment or to change termination for monitoring compatibility with an operator. Compatible with most operator brands with electronic controls.

CONTENTS

- **CPT215 Extrusion**
- **CPT215 End Kit:**
 - (1) Wired plug
 - (2) Cages
 - (2) Caps
 - (2) #6 x 1-1/4-in. Phillips flathead stainless steel screws
 - Non-wired plugs:
 - **End Kit, model: CPT215-ENDKIT-T1**
 - (1) 8.2K terminated plug (green)
 - (1) Non-terminated plug (black)
 - **End Kit, model: CPT215-ENDKIT-T2**
 - (1) 10K terminated plug (blue)
 - (1) Non-terminated plug (black)
 - **End Kit, model: CPT215-ENDKIT-T3**
 - (1) Diode capacitor plug (red)
 - (1) Non-terminated plug (black)
 - **End Kit, model: CPT215-ENDKIT-U**
 - (1) 8.2K terminated plug (green)
 - (1) 10K terminated plug (blue)
 - (1) Diode capacitor plug (red)
 - (1) Non-terminated plug (black)
 - **5-ft. Edge Kit, model: CPT215-EDGE-5-T1T2**
 - (1) 8.2K terminated plug (green)
 - (1) 10K terminated plug (blue)
 - (1) Non-terminated plug (black)
 - 5-ft. ME123-CA3 mounting channel

REQUIRED

- Operator manual for detailed connection instructions
- Mounting channel: ME123-C, ME123-C1, ME123-C3, ME123-CA3, ME123-C2175, ME123-C7
- #2 Phillips screwdriver
- PVC cutting tool (optional 224-101: Extrusion Cutter)
- Mounting hardware:
 - Mounting channel: #6-8 self-drilling screws
 - Gate/vertical mounting set screw: #8 x 1/2-in. lath screw

SUGGESTED

- Multimeter capable of reading 10K Ω
- MET-101: Edge Tester

OPTIONAL

- **Wireless Connections**
 - Miller Edge wireless edge transmitter/receiver system
- **Wired Connections**
 - 18-22 gauge wire
 - Junction box(es) and mounting hardware
 - Coil cord
 - Retracting reel (non-monitored systems only)
 - Interface module (consult operator manual for the required monitoring configuration)

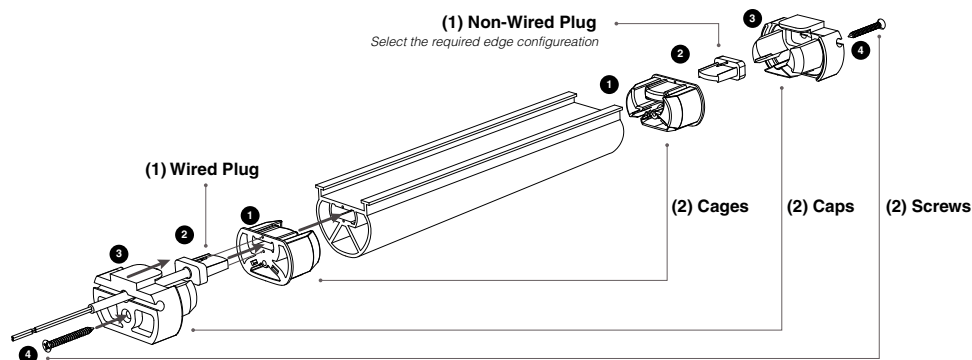

IMAGE 1: CPT215 Assembly

CPT215_INST_20240628

I. INSTRUCTIONS

1. Measuring & Cutting

For Doors & Horizontal Mounting

- a. Determine the length of the sensing edge by measuring the door section width.
- b. Cut mounting channel to the section length.
- c. Cut the extrusion 2-inches less than the section width.

For Gates & Vertical Mounting

- a. Determine the desired overall sensing edge assembly length.
- b. Cut the mounting channel to overall sensing edge assembly length.
- c. Cut the extrusion to 1-1/2-inches shorter than the assembly length to account for the end components.

2. Assembly IMAGE 1

- a. Wired end:
 - i. Install cage into the end of the CPT215 extrusion.
 - ii. Insert the wired plug into the cage, aligning the pins with the cage holes.
 - iii. Install cap by pressing firmly, ensuring there are no gaps between the extrusion and the end components.
 - iv. Using a #2 Phillips screwdriver, install one stainless steel screw into the cap.
- b. Non-wired end:
 - i. Install cage into the end of the CPT215 extrusion.
 - ii. Insert one non-wired plug (green = 8.2K, blue = 10K, red = diode capacitor, black = non-terminated) into the cage, aligning the pins with the cage holes.
 - iii. Install cap by pressing firmly, ensuring there are no gaps between the extrusion and the end components.
 - iv. Using a #2 Phillips screwdriver, install one stainless steel screw into the cap.

3. Mounting Channel Installation

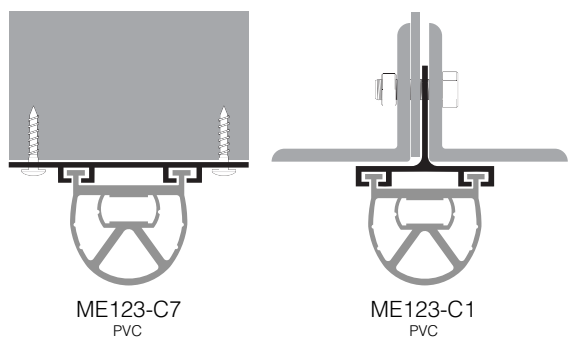
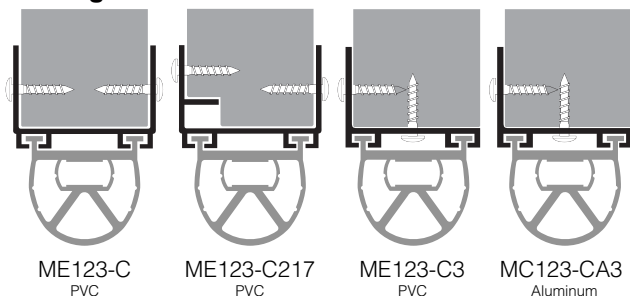

IMAGE 2: Mounting Channel Styles & Possible Hardware Placement

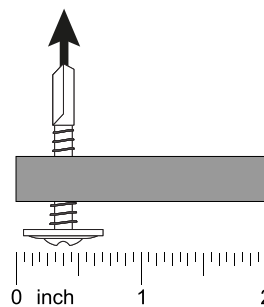

IMAGE 3: Installing a #8 x 1/2-in. lath screw

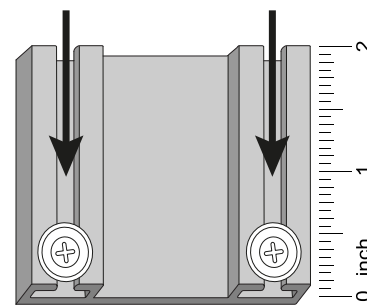

IMAGE 4: Installing the assembled edge (gates)

For Doors & Horizontal Mounting

- Pre-drill mounting holes into the channel.
 - TechTip:** If needed, notch the L or U-shaped channel at each end to clear any bottom corner brackets.
- Align the channel with the edges of the bottom door section. Attach the mounting channel to the leading edge using #6-8 self-drilling screws (not provided) prior to installing the extrusion as shown. **IMAGE 2**
- Starting at one end of the mounting channel, gently slide the sensing edge into the channel. When complete, the wire should be facing the operator side.
- Adjust the close limits on the motor for a maximum compression of .25-in. (6 mm).

TechTip: To compensate for floor irregularities, use an L or U-shaped mounting channel. When installing, gently curve it up or down to close any gaps between the edge and the floor, wall, or other adjacent permanent fixture.

For Gates & Vertical Mounting

- Pre-drill mounting holes into the channel.
- Attach the mounting channel to the leading edge using #6-8 self-drilling screws (not provided) prior to installing the extrusion as shown. **IMAGE 2**
- Note: Channel is shipped in 5-foot sections. If needed, install sections closely together, avoiding gaps.
- In the bottom 1/2-inch of the mounting channel, insert a #8 x 1/2-in. lath screw (not provided). **IMAGE 3**
- Starting at the top of the mounting channel, gently slide the sensing edge into the channel, stopping at the lath screw. **IMAGE 4**

4. Connection

OPTION 1: DIRECT HARDWIRED METHOD (for Gates & Vertical Mounting)

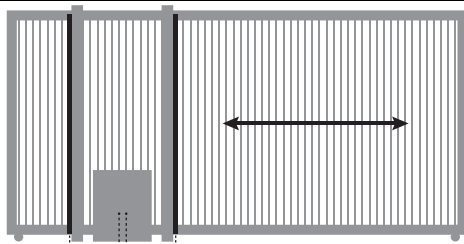

Required

- (1) Junction box
- Mounting screws
- Wire end caps
- 18-22 gauge wire

Installation

- Consult the Miller Edge transmitter/receiver installation instructions for wiring of the sensing edge.
- For proper connection to operator inputs, consult the operator manual.

OPTION 2: WIRELESS METHOD (for Doors & Gates)

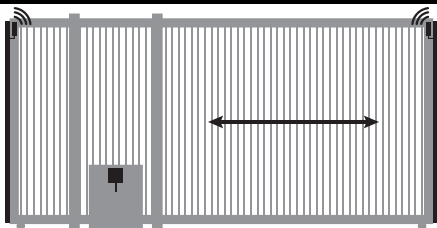

Required

- Miller Edge wireless edge transmitter/receiver system

Installation

- Consult the Miller Edge transmitter/receiver installation instructions for wiring of the sensing edge.
- For proper connection to operator inputs, consult the operator manual.

OPTION 3: COIL CORD METHOD (for Doors & Horizontal Mounting)

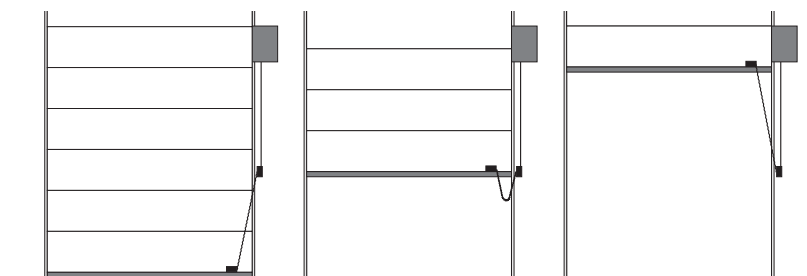

Required

- (2) Junction boxes
- Mounting screws
- Wire connectors
- 18-22 gauge wire

Note: For specific operator input connection diagrams and instructions, please consult your operator manual.

Installation

- Mount the first junction box on the bottom bar of the door.
- Run the sensing edge lead wire into the junction box.
- Mount the second junction box on an adjoining wall, midway between the floor and the operator.
- With the door in the closed position, secure the coil cord to the first junction box.
- Then run it, fully stretched, to the second wall mounted junction box so the stretched length is equal to one-half of the door opening.
- Secure the coil cord into the wall junction box and trim the coil cord. This assures the excess coil cord will not get caught or hang in the opening of the door.
- Secure 18-22 gauge wire into the second wall-mounted junction box and hard wire to the operator sensing edge terminals. For proper connection to operator inputs, please consult the operator manual.

OPTION 4: RETRACTING REEL METHOD (for Doors & Horizontal Mounting)

CAUTION: Not suitable for monitored sensing edge configurations (use with non-terminated plug only)

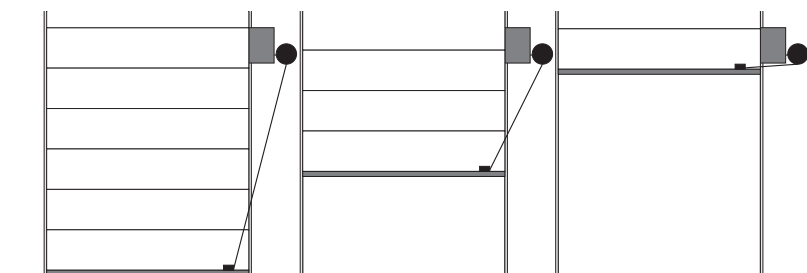

Required

- (1) Junction box
- Mounting screws
- Wire connectors
- 18-22 gauge wire

Note: For specific operator input connection diagrams and instructions, please consult your operator manual.

Installation

Caution: Not suitable for monitored sensing edge configurations (use with non-terminated plug only)

- Mount the junction box on the end stile or bottom bar of the door.
- Run the sensing edge lead wire into the junction box.
- Mount the retracting reel on an adjoining wall, near the operator.
- With the door in the closed position, secure the retracting reel cable to the junction box. The cable should freely extend, without rubbing, in and out of the retracting reel for the duration of the open/close cycle.
- Using the 18-22 gauge wire, hardwire the retracting reel to the sensing edge terminals of the operator. For proper connection to operator inputs, please consult the operator manual.

II. TROUBLESHOOTING

Suggested

- Edge Tester (MET-101)
- Multimeter (capable of measuring 10K)

Test

1. Test the sensing edge for function by verifying the termination of the edge using the appropriate method:

Sensing Edge Termination	Miller Edge Tester (MET-101)	Multimeter Resistance
8.2K ohm (T1)	NA	~7.5-8.5K ohms
10K ohm (T2)	✓	~9.5-10.5K ohms
Diode Capacitor (T3)	✓	NA
Non-Terminated	✓	∞ ohms

2. Press the sensing edge to confirm the resistance is less than 500 ohms.

Tech Tip

To determine sensing edge termination, note the color of then non-wired plug: **IMAGE 1**

PLUG COLOR	TERMINATION	TYPE
Green	8.2K ohm resistor	T1
Blue	10K ohm resistor	T2
Red	Diode capacitor	T3
Black	Non-terminated	-



III. TECH SUPPORT

For additional assistance, contact Miller Edge Tech Support: Call 800-220-3343 and select “option 2” or email techsupport@milleredge.com.

IV. GENERAL SPECIFICATIONS

Color	Black
Maximum Length	50 ft.
Sensitivity	Nominal 3-5 lbf
Lead Wire	12 in., 22 gauge, SJTO
Wire Outlet Location	Universal end plug
Electrical Maximum	24 volts AC/DC, 1/2 amp
Electrical Configuration	Normally open non-terminated or terminated: 8.2K Ω, 10K Ω, or diode capacitor options
Temperature Range	Meets or exceeds UL Requirement
Exterior Materials	Extrusion: Flexible PVC, conductive polymer; Ends: Molded polymer
Contact Element	Conductive polymer
Agency Approvals	UL 325 Recognized Component, CE certificate of compliance

V. MAINTENANCE

It is strongly recommended that users test sensing edges at least once per month. Check the sensing edge for cuts, loss of sensitivity, or water damage. Also check for signs of damage to cables or connection points. Compress the sensing edge 2-in. from both ends and in the center and observe that it sends an electric signal to the controls. Refer to your operator manual for detailed instructions about motor connections.

VI. WARRANTY

CPT215 carries a **2-year warranty** from date of shipment from Miller Edge for credit or replacement. This warranty applies to normal use, which is found to have defective materials or workmanship, as determined solely by an authorized factory representative. This warranty is void where evidence of misuse or abuse is present. This warranty covers repair or replacement of the purchased product only; product installation/labor charges are not covered. Miller Edge manufactures its products to meet stringent specifications and cannot assume responsibility for those consequences arising from improper installation or misuse. Installation instructions and testing procedures provided by Miller Edge must be followed for proper operation and maintenance.

VII. ACCESSORIES

Contact your sales representative about accessories for your installation.