

# Sensing Edges

## MU21



## TOUCH SENSITIVE SIGNALING

MU-style sensing edges mount directly to the bottom of a commercial sectional door or material handling system, no mounting channel required. The durable vinyl jacket that covers the internal switch forms two top tabs that were designed to wrap around a leading edge. The flexibility of the MU21 sensing edge allows it to conform to slight irregularities in the floor or other surface. When touched lightly, the sensing edge will send an immediate signal to operator controls to stop and/or reverse door operation.



### APPLICATIONS

- Commercial sectional doors
- Material handling systems

### FEATURES

- Optimum size for 2-inch thick surfaces
- Custom manufactured to user specifications for color, length, and outlet location
- Mounts vertically or horizontally
- 5-6 inch end flaps create a complete seal and can be trimmed for custom fit
- Extended color options including yellow chemical resistant XR5 jacket
- Flexible and will conform to slight floor irregularities
- Sealed assembly impervious to dust and debris
- Patented Alumaglas™ for superior performance (electric option)
- UL 325 Recognized Component
- 1-year warranty
- Made in USA

610-869-4422  
[www.milleredge.com](http://www.milleredge.com)





# Sensing Edges

## MU21

### GENERAL SPECIFICATIONS

Color	● Gray, ● Black, ● Yellow, ● Y/B Stripe, or ● XR5 (yellow)
Length	Order in 1/4 in. increments (manufacturing tolerance $\pm 1/4$ in.)
Maximum Length	Electric ⚡: 150 ft., Air-Wave 🌊: 60 ft., Pneumatic 🌬️: 18 ft.
Sensitivity	Nominal 4-8 lbf
Lead Wire	SJTO, 18 gauge, 2 ft. length
Wire Outlet Location	Universal, left, or right
Electrical Maximum	24 volts AC/DC, 1/2 amp
Electrical Configuration	Normally open
Operating Temperature	Meets or exceeds UL requirement
Exterior Materials	Heavy duty reinforced PVC
Contact Element	Alumaglas™
Agency Approvals	c  us UL 325 Recognized Component

### OPTIONS

#### Configurations:

- Monitored
  - 2-Wire ⚡
    - 10K resistor
    - 8.2K resistor
    - Diode capacitor
  - 4-Wire ⚡
- Non-Monitored
  - 2-Wire ⚡
  - Air-Wave 🌊
  - Pneumatic 🌬️

#### Other Options:

- XR5 chemically resistant cover (yellow)
- Series connect option
- Coil cord attached
- 10 ft. lead wire

### WIRE OUTLET LOCATION OPTIONS

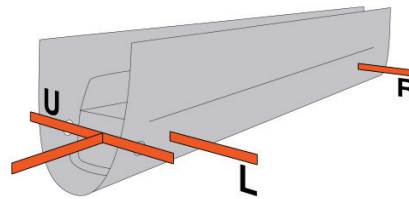

### DIMENSIONS

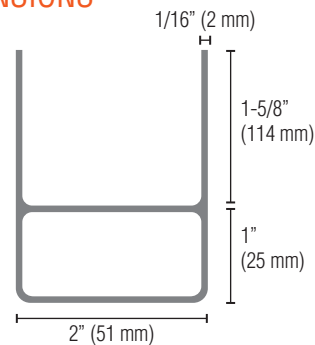

### RELATED PRODUCTS



TRANSMITTERS/RECEIVERS



INTERFACE MODULES



COIL CORDS



RETRACTING REELS



JUNCTION BOXES



EDGE TESTER



Contact Miller Edge to ensure compatibility.

© Miller Edge, Inc. All rights reserved  
MU21\_20220607