

Sensing Edges

MU22



TOUCH SENSITIVE SIGNALING

Designed for application on two-inch thick doors, MU22 can be custom manufactured to accommodate the required length for commercial sectional doors and material handling systems. MU22 is engineered to send an immediate signal to stop and/or reverse operator controls when lightly touched. With the ability to mount vertically or horizontally and no mounting channel required, MU22 is a UL 325 Recognized Component that is flexible, durable, and dependable. Available in various colors, lengths, and outlet locations to meet customer specifications.



APPLICATIONS

- Commercial sectional doors
- Material handling systems

FEATURES

- Optimum size for 2-inch thick surfaces
- Custom manufactured to user specifications for color, length, and outlet location
- Mounts vertically or horizontally
- 5-6 inch end flaps create a complete seal and can be trimmed for custom fit
- Extended color options including yellow chemical resistant XR5 jacket
- Flexible and will conform to slight floor irregularities
- Sealed assembly impervious to dust and debris
- Patented Alumaglas™ for superior performance (electric option)
- UL 325 Recognized Component
- CE certificate of compliance
- 1-year warranty
- Made in USA

610-869-4422
www.milleredge.com





Sensing Edges

MU22

GENERAL SPECIFICATIONS

Color	● Gray, ● Black, ● Yellow, ● Y/B Stripe, or ● XR5 (yellow)
Length	Order in 1/4 in. increments (manufacturing tolerance $\pm 1/4$ in.)
Maximum Length	Electric ⚡: 150 ft., Air-Wave 🌊: 60 ft., Pneumatic 🌬️: 18 ft.
Sensitivity	Nominal 4-8 lbf
Lead Wire	SJTO, 18 gauge, 2 ft. length
Wire Outlet Location	Universal, left, or right
Electrical Maximum	24 volts AC/DC, 1/2 amp
Electrical Configuration	Normally open
Operating Temperature	Meets or exceeds UL requirement
Exterior Materials	Heavy duty reinforced PVC
Contact Element	Alumaglas™
Agency Approvals	cRU us UL 325 Recognized Component, CE certificate of compliance

OPTIONS

Configurations:

- Monitored
 - 2-Wire ⚡
 - 10K resistor
 - 8.2K resistor
 - Diode capacitor
 - 4-Wire ⚡
- Non-Monitored
 - 2-Wire ⚡
 - Air-Wave 🌊
 - Pneumatic 🌬️

Other Options:

- XR5 chemically resistant cover (yellow)
- Series connect option
- Coil cord attached
- 10 ft. lead wire

WIRE OUTLET LOCATION OPTIONS

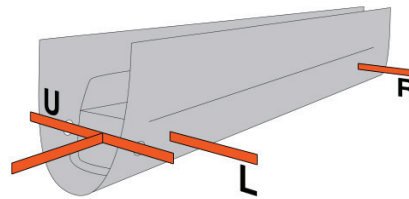

DIMENSIONS

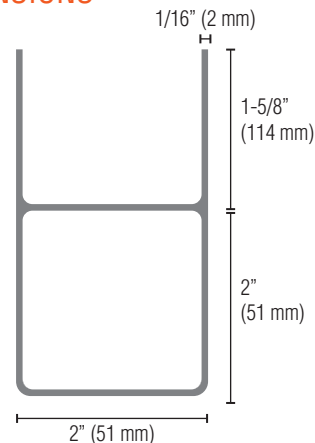

RELATED PRODUCTS



TRANSMITTERS/RECEIVERS



INTERFACE MODULES



COIL CORDS



RETRACTING REELS



JUNCTION BOXES



EDGE TESTER



Contact Miller Edge to ensure compatibility.

© Miller Edge, Inc. All rights reserved
MU22_20220607