

# Custom Sensing Edge

MUxx



## TOUCH SENSITIVE SIGNALING

The MUxx sensing edge is completely customizable to your exact specifications for profile height and width, active edge length, and outlet location. When touched lightly, the edge will send an immediate signal to operator controls to stop and/or reverse door operation. MUxx is covered in a durable vinyl jacket, and can be mounted horizontally or vertically. The top mounting tabs of this versatile sensing edge wrap around the leading edge of a sectional or hangar door. Contact your Miller Edge Sales Representative to fully customize your MUxx for your unique application.

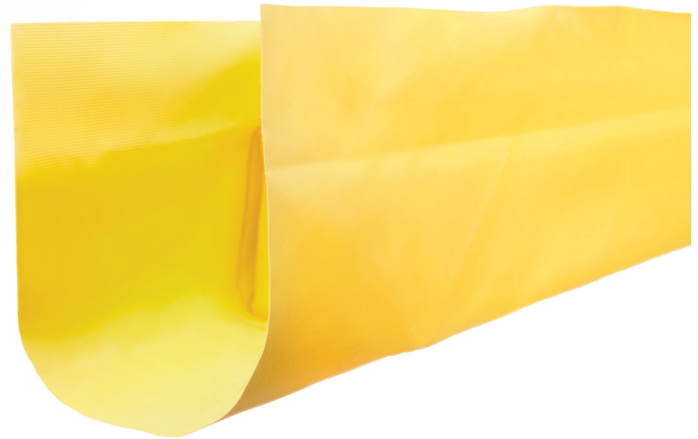

### APPLICATIONS

- Aircraft hangar doors
- Commercial sectional doors
- Material handling systems

### FEATURES

- Fully customizable sensing edge: profile height and width, active edge length, and outlet location
- Standard 6 inch end flaps; custom lengths available
- Mounts vertically or horizontally
- End flaps create a complete seal and can be trimmed for custom fit
- Sealed assembly impervious to dust and debris
- Patented Alumaglas™ for superior performance (electric option)
- Extended color options including chemical resistant yellow XR5 jacket
- UL 325 Recognized Component
- CE certificate of compliance
- 1-year warranty
- Made in USA

610-869-4422  
[www.milleredge.com](http://www.milleredge.com)





# Custom Sensing Edge

## MUxx

### GENERAL SPECIFICATIONS

Color	● Gray, ● Black, ● Yellow, ● Y/B Stripe, or ● XR5 (yellow)
Length	Order in 1 in. increments (manufacturing tolerance +/- 1/2 in.)
Maximum Length	Electric ⚡: 150 ft., Air-Wave 🌊: 60 ft., Pneumatic 🌬️: 18 ft.
Sensitivity	Based on custom dimensions
Lead Wire	SJTO, 18 gauge, 2 ft. length
Wire Outlet Location	Universal, left, or right
Electrical Maximum	24 volts AC/DC, 1/2 amp
Electrical Configuration	Normally open
Operating Temperature	Meets or exceeds UL requirement
Exterior Materials	Heavy duty reinforced PVC
Contact Element	Alumaglas™
Agency Approvals	UL US UL 325 Recognized Component, CE certificate of compliance

### OPTIONS

#### Configurations:

- Monitored
  - 2-Wire ⚡
  - 10K resistor
  - 8.2K resistor
  - Diode capacitor
  - 4-Wire ⚡
- Non-Monitored
  - 2-Wire ⚡
  - Air-Wave 🌊
  - Pneumatic 🌬️

#### Other Options:

- Coil cord attached
- Extra lead wire
- XR5 chemically resistant cover (yellow)
- Series connect option with optional quick micro connectors

### DIMENSIONS

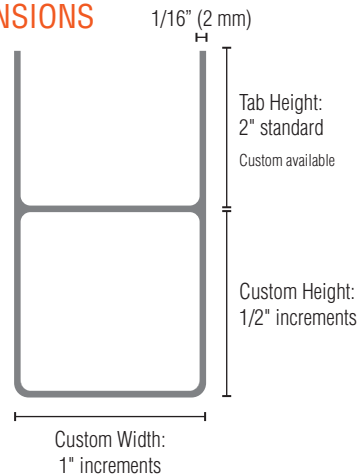

### HANGAR DOORS

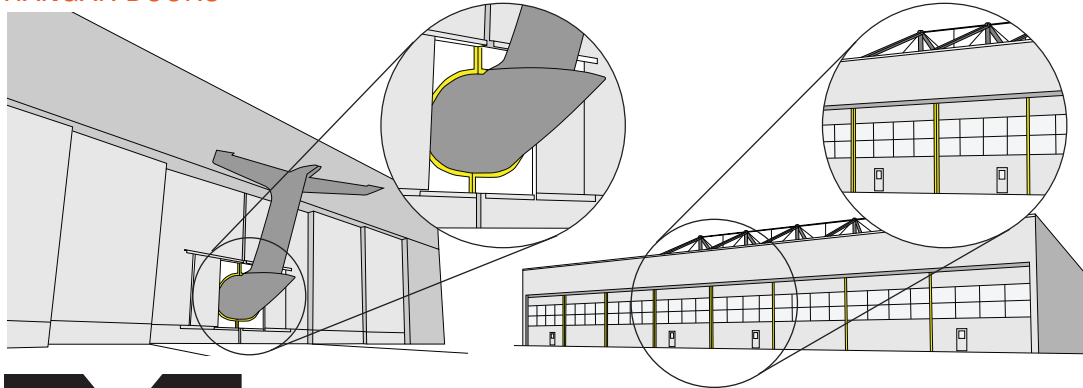

### RELATED PRODUCTS



TRANSMITTERS/RECEIVERS



INTERFACE MODULES



COIL CORDS



RETRACTING REELS



JUNCTION BOXES



EDGE TESTER

Contact Miller Edge to ensure compatibility.

© Miller Edge, Inc. All rights reserved  
MUxx\_20220512