

Single-Channel Wireless System

MWRT12B, MWRTA12B



WIRELESS DOOR EDGE SOLUTION

Avoid visible cords and reels with this non-monitored single-channel edge system. Designed to provide a wireless signal transmission from the sensing edge to motor controls, this reliable system has on-board diagnostics for easy setup and troubleshooting. The transmitter comes standard with a NEMA 4 weather-proof enclosure and both the receiver and transmitter have a compact design that allow for easy troubleshooting via the transparent cases. The transmitter is available with an optional audible alarm that activates when the battery has 25% of its life remaining.



APPLICATIONS

- Motorized doors
- Automated gates

FEATURES

- Easy to configure
- Non-monitored system ideal for operators manufactured prior to:
 - Doors: August 2010
 - Gates: January 2016
- NEMA 4 transmitter built to endure rugged environments
- 2-year warranty

Image:
Single-Channel Wireless Edge System:
MWR12B receiver + MWTA12B transmitter
with low battery alarm

800-220-3343
www.milleredge.com

© Miller Edge, Inc. All Rights Reserved





Single-Channel Wireless System

MWRT12B, MWRTA12B

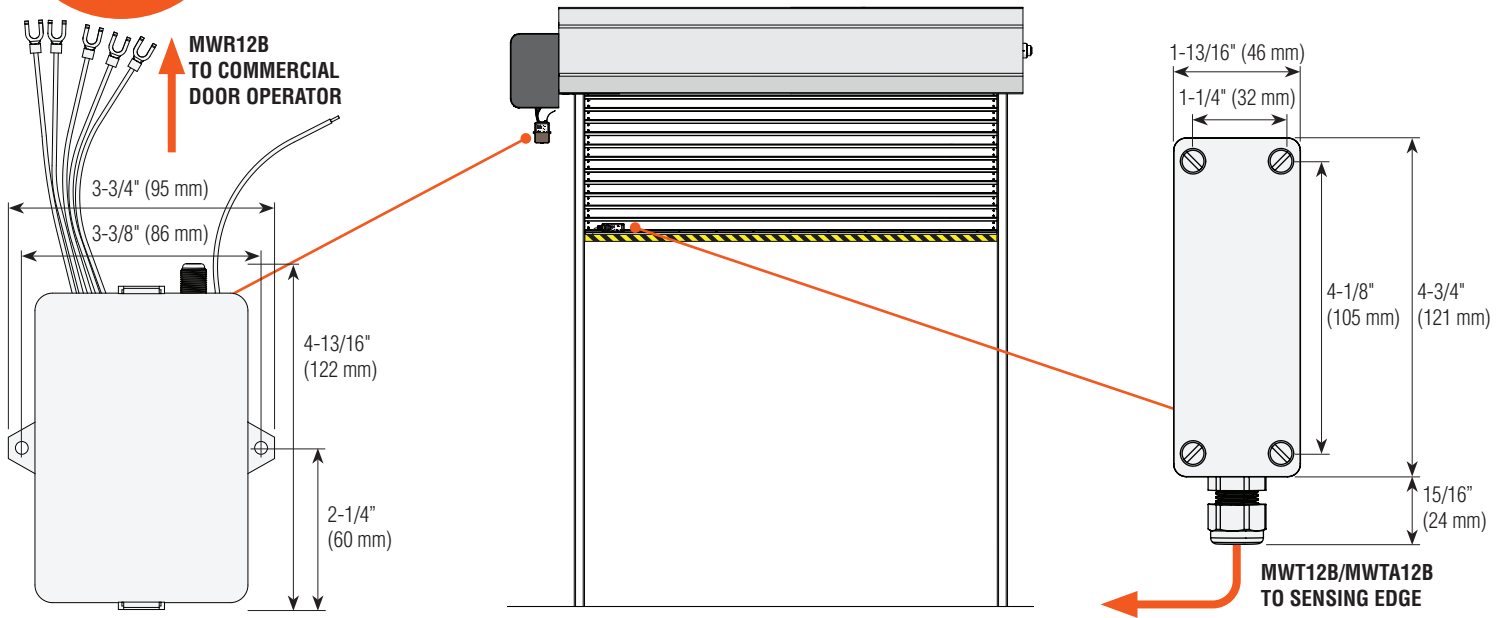

GENERAL SPECIFICATIONS

PERFORMANCE

Response Time	70 milliseconds
Operating Temperature	0°F to 130°F (-18°C to 55°C)
Frequency	318 MHz
Operating Range	100 ft. (optimal conditions)
Coding	Selectable 9 pole, 2 position DIP switch
Agency Approvals	FC

	MWR12B RECEIVER	MWT12B TRANSMITTER	MWTA12B TRANSMITTER
ELECTRICAL			
Power Source	12-24 volts AC/DC nominal Nominal 60 mA, 140 mA activated	(2) 1.5 volts AA alkaline batteries, 2-year expectancy	(2) 1.5 volts AA lithium batteries, 2-year expectancy
Input/Output	Output: N.O., N.C.	Input: 2-wire N.O. sensing edge	Input: 2-wire N.O. sensing edge
PHYSICAL			
Dimensions	3-3/4"W x 4-13/16"H x 1-1/4"D (95 x 122 x 32 mm)	1-13/16"W x 5-3/4"H x 1-3/4"D (46 x 146 x 44 mm)	1-13/16"W x 5-3/4"H x 2-1/8"D (46 x 146 x 54 mm)
Weight	4.6 oz.	7.2 oz.	7.2 oz.
Enclosure Material	Polycarbonate	Polycarbonate	Polycarbonate
TX Low Battery Alert	-	-	Alarm; 80-95 dB at 2'
LED Indicators	Power, channel 1	Transmit	Transmit
Antenna	Attached wire or F connector	-	-
Wiring Connections	Integral 18" wiring with #6 spade lugs	-	-
Degree of Protection	-	NEMA 4	NEMA 4



OPTIONS

- MWRT12B: MWR12B receiver + MWT12B transmitter
- MWRTA12B: MWR12B receiver + MWTA12B transmitter with low battery alarm

RELATED PRODUCTS

- ANT-RC: 318 MHz Rigid Antenna, Wire Insulated

Contact Miller Edge to ensure compatibility.

© Miller Edge, Inc. All rights reserved
MWRT12B-MWRTA12B_Spec_20240412